

Owners Manual



Thank You for Purchasing a Split-fire Log Splitter!

*We appreciate having you as our customer
and wish you many years of safe and satisfactory operation
with your machine.*

SPLIT-FIRE SALES INC.

*285633 Airport Road
Norwich, ON NOJ 1P0
Canada*

1-877-548-3473 / 519-468-3647

CONTENTS

HOW TO USE YOUR OWNERS MANUAL	2
PRODUCT IDENTIFICATION	4
WARRANTY	6
SAFETY	
SAFETY LABELS	8
WOOD HANDLING	7
OPERATION SAFETY	10
WORKSITE SAFETY	12
SAFETY CHECKLIST	16
OPERATION AND MAINTENANCE	
BEFORE OPERATION	14
OPERATION	15
STORAGE	15
TOWING	
COUPLER OPERATION INSTRUCTIONS	16
TOWING YOUR LOG SPLITTER	17
GENERAL PARTS LIST	18-19
CHECKLIST	21

HOW TO USE YOUR OPERATOR'S MANUAL

This owner's manual is a very important part of your new machine and should remain a permanent part of it. If the machine is sold, the operator's manual must go with it.

By reading the operator's manual you will help yourself and others avoid unnecessary personal injury and/or damage to the machine. The information recorded in this manual will help you use this machine safely and effectively. Once you know how to operate the machine correctly and safely, you can train others to operate the machine as well.

If your machine has been ordered with any options or attachments please refer to the individual operator's manual that is included with that individual accessory.

The machine that is used in this manual for illustration may differ slightly from your model. It will be similar enough to help you understand our instructions.

Throughout this manual the terms "Left Hand" and "Right Hand" will be used. These sides are determined when standing behind the engine or three point hitch and facing the knife or far stop of the machine. Also "Back" and "Front" will be used. On the self-contained log splitter the "Back" is referred to the engine side and the hitch is the "Front". On the 3pt hitch log splitter the "Back" is the 3pt mount and the "Front" is the stop on the far end of the splitter.

Your machine has been tested and inspected to ensure good performance prior to leaving the factory.

While reading the manual, important messages are used to bring the operator's attention where there may be safety concerns relating to machine damage and important servicing

Information. Please read all these messages to avoid personal injury and machine damage. The three main messages will start with:

WARNING!!! which suggests, a strong chance of personal injury or death to the operator or bystanders if procedures are ignored.

IMPORTANT: which suggests, a strong chance of potential damage to the machine may occur if procedures are ignored.

NOTE: suggests to the operator, General information given to help the operator to operate or service the machine.

PRODUCT IDENTIFICATION

If you ever need to contact your dealer or the manufacture for parts or questions regarding the operation or servicing of the machine, it is important to have the model number as well as all the necessary identification numbers. Using the sample pictures below you can find the necessary number to complete the spaces below.

Date of Purchase:

Dealer Name:

Dealer Phone Number:

Frame Serial Number: (XX XX XX)

Engine Serial Number (If equipped with engine): (XXXXXXXX)

ENGINE SERIAL NUMBER

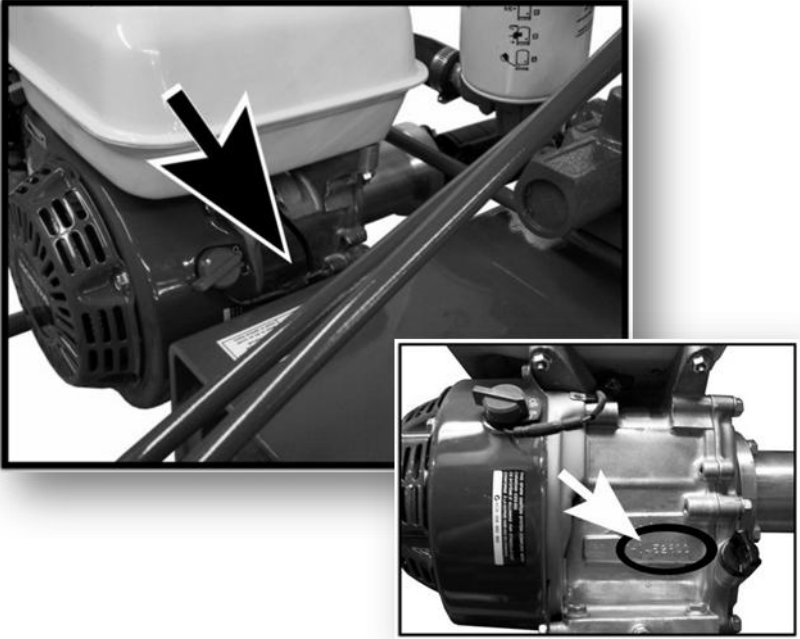

FRAME SERIAL NUMBER



WARRANTY

Split-fire Sales Inc. guarantees the original purchaser of any new Split-fire machine, that the same is free of defects in workmanship or materials that may cause performance failure, subject to the conditions hereafter.

Split-fire must be contacted before the problem on the machine has been fixed. Split-fire will diagnose the problem and authorize any warranty work that will be allowed. If Split-fire does not authorize or parts are not sent from Split-fire Warranty will not be applicable.

This guarantee is limited to a period of one year from the date of purchase. Replacement of any defective part is free of charge FOB Split-fire sales Inc. If Split-fire requires the parts to be returned to Split-fire, Split-fire will pay for that shipping.

This guarantee does not apply to engines or other parts that are manufactured and guaranteed by the manufacture thereof, nor does this apply with respect to any part or product that:

1. has original parts removed or otherwise altered without specific authorization beforehand from Split-fire Sales Inc.
2. has had placed upon or attached to it any part or product not sold or approved by Split-fire Sales Inc.
3. has been damaged or is not used in conformity with the applicable instruction for the machine.
4. has not been properly adjusted, or maintained by the owner.
5. has been adjusted or altered to increase the performance of the machine.

This guarantee is in lieu of, and excluded all other guarantees and conditions of merchantability and fitness for a purpose. Acceptance of a Split-fire Sales product constitutes an agreement that Split-fire Sales shall have no liability for any special or consequential damage.

NEVER HANDLE WOOD ON THE SAWN ENDS; BLOCKS SHOULD ALWAYS BE HELD BY THE BARK SIDES!



DANGER

NEVER! HANDLE WOOD BY THE SAWN ENDS!
BLOCKS SHOULD ALWAYS BE HELD ON THE BARK SIDES!

MANIPULER LE BOIS SUR LE COTE DE L'ECORCE SEULEMENT. **NE JAMAIS** MANIPULER LES BUCHES PAR LE BOUT QUI EST SCIE!

REMOVE HANDS IMMEDIATLY WHEN KNIFE CONTACTS WOOD!

ENLEVER LES MAINS IMMEDIATEMENT QUAND LE COUTEAUX ENTRE EN CONTACTE AVEC LE BOIS!

The main warning sign is a vertical rectangle with a black and white diagonal striped border. At the top, the word "DANGER" is written in large, bold, black capital letters. Below it, the text "NEVER! HANDLE WOOD BY THE SAWN ENDS! BLOCKS SHOULD ALWAYS BE HELD ON THE BARK SIDES!" is written in bold, black capital letters. A horizontal line follows. Below the line, the text "MANIPULER LE BOIS SUR LE COTE DE L'ECORCE SEULEMENT. NE JAMAIS MANIPULER LES BUCHES PAR LE BOUT QUI EST SCIE!" is written in black capital letters. In the center, there are two black silhouette diagrams. The top diagram shows a hand holding a piece of wood by its sawn end, with another hand holding the other end. A large black 'X' is superimposed over this diagram. The bottom diagram shows two hands holding a piece of wood by its bark sides. Below the diagrams, the text "REMOVE HANDS IMMEDIATLY WHEN KNIFE CONTACTS WOOD!" is written in bold, black capital letters. A horizontal line follows. At the bottom, the text "ENLEVER LES MAINS IMMEDIATEMENT QUAND LE COUTEAUX ENTRE EN CONTACTE AVEC LE BOIS!" is written in black capital letters.

SAFETY LABELS

The machine safety labels shown in the section below are very important. They are placed in areas on the machine that draw the attention of the operator to potential safety hazards on the machine. If at any time the stickers are removed, or come off, contact your dealer or the manufacturer immediately for replacement decals.

The operator's manual explains the potential safety hazards in detail associated to each decal. Special attention should be kept for these recommendations. They are outlined for your safety.

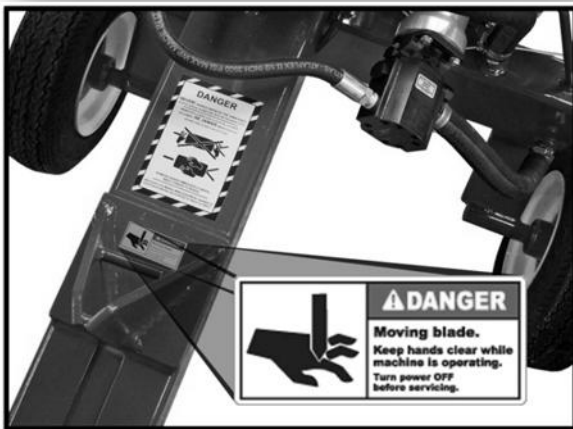
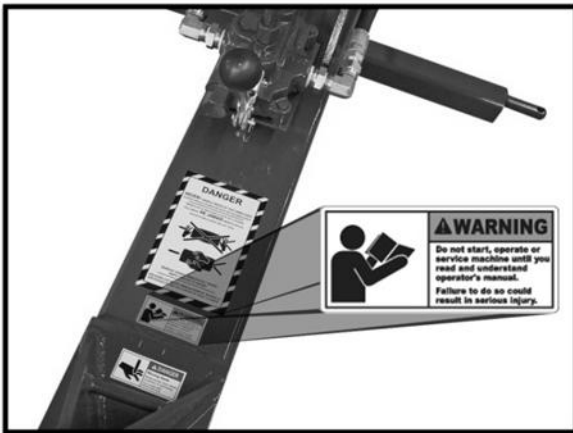

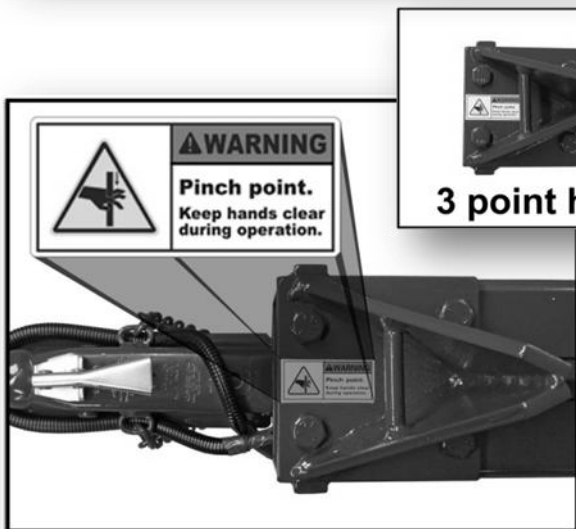

OPERATOR TRAINING REQUIRED

WARNING!!!

✓ Carefully read and understand all the instructions pertaining to the log splitter in the operator's manual before operating your new machine. Anyone who operates or services this machine must read the owner's manual first. If any doubt or question arises about the safe and/or correct method of performing anything in this manual, contact one of our representatives at our head-office.

✓ Avoid accidents by being alert and recognizing potential hazards. Not all possible circumstances can be anticipated in this manual. Keep your log splitter and work area safe for yourself and others. Proper care and safety is your responsibility.

NOTE! If your log splitter is equipped with a Honda engine or any other attachments, be sure to read those manuals.

Warning:

The engine exhaust from this product contains chemicals known to the State of California to cause cancer, birth defects or other reproductive harm.

✓ All operators must have the necessary training and skills to operate and the machine properly and safely. Use the controls correctly, and follow the safety signs and recommendations.

✗ Never allow untrained persons to operate or service the equipment.

✗ Never let persons under the age of 18 operate the log splitter.

- ✓ The owner is responsible for accidents and injuries to themselves and/or other persons operating their machine. If others are permitted to use this machine it is the responsibility of the owner to train users.
- ✓ New users may operate this machine in a clear, unobstructed area under the supervision of an experienced operator, only after they have read and understand the owner's manual.

SAFE OPERATION

- ✓ Only allow responsible adults who are familiar with the instructions to operate this machine.
- ✓ Inspect your machine each time before use. Special attention should be taken that all guards are in place, damaged or missing parts are replaced, and that all the safety decals highlighted in the safety labels section are in place on the machine.
- ✓ Each time you operate your log splitter, ensure that the handle on the hydraulic valve returns to centre position. Move handle both ways and if it sticks, immediately call the dealer or manufacture for replacement parts.
- ✓ Only one person may operate the machine at any time. More than one operator greatly increases the chance of personal injury or death.
- ✗ Never leave machine unattended while running.
- ✗ Never operate machine when under the influence of alcohol or drugs.
- ✗ Do not alter; add accessories, or attachments to your log splitter without the approval of the manufacturer. Doing

any of the above without the manufacturer's approval WILL VOID THE WARRANTY. If attachments have been added with the approval of the manufacturer, be sure to keep safety labels visible.

✓ Your machine is designed to split wood only! Stones, metal, brush, gravel, and other foreign objects will cause damage to the machine and increase the chance of personal injury or death.

✗ It is not recommended to split wood across the grain. This may cause wood to explode out sideways and cause personal injury or death.

Worksite Safety

✓ Keep area around the log splitter clear from tall grass, debris, tools, and pieces of wood at all times.

✓ Operate log splitter on level surface only.



✗ Do not operate your machine in enclosed areas. Your engine produces Carbon monoxide, which is extremely dangerous if used in enclosed area. (E.g. Garage)

✗ Do not operate machine when distracted by others. Keep children and pets at least 25 feet away from the work area to protect them from possible injuries. Keep other distractions such as radio, television etc. away.

✓ Only use machine during daylight hours. Use of this machine without proper lighting can lead to personal injury or death.

✓ Protect yourself at all times while operating your machine. Safety glasses, steel-toed boots and ear protection should be worn at all times. Loose clothing is also not permitted around your machine.



✓ Keep hands and body parts clear of cutting blades and end stops at all times.

✗ Never handle wood on the sawn ends; blocks should always be carried by the bark sides.



✗ Hands should not be lower than half way down the sides of the block when splitting. If hands are lower and a log falls, fingers may get pinched between the log and the shelves.

✗ Do not transport this machine while the motor is running. This may cause permanent damage to your engine.

✓ Always disconnect the spark plug when the log splitter is not in use or is being serviced.

✓ If your machine is equipped with a log lifter, it is recommended that the operator stands on the right side of the machine and follows the wood up with their hand to stabilize the log and keep it from rolling off of the bed. If the machine does not have a log lifter, the operator can stand either on the left or the right side.

OPERATION & MAINTENANCE

BEFORE OPERATION AND MAINTENANCE

Be sure that the knife is free of burrs. If there are burrs on the knife take a sander and lightly go over it sanding the burr into the knife. Do not try to sand the burr out of the knife.

Check the sight glass on the reservoir and make sure that the oil is at least half way up the sight glass when the knife is on the backstroke (closest to the engine). On 3-pt hitch models, ensure that there is enough oil in the tractor. See your tractor owner's manual for oil level.

When new, run splitter without oil or grease on the slider until it moves freely. If slides are oiled they will collect the dust and dirt and will wear out faster.

Check the wear on the slide pads by moving the top of the knife with your hand. If the top moves more the 3/8" it is time to replace the slide pads. Stop immediately and order new slide pads from your dealer or manufacture. If machine is used with worn pads, damage to the frame, cylinder and other parts of the machine may occur, which will not be covered by warranty.

The hydraulic oil should be changed every 2 years or every 1000 face cord of wood. AW32 Hydraulic oil is recommended for your machine. If you want to use any other oil contact the manufacture for their approval.

The hydraulic oil filter should be changed after the first 50 and then every 250 hours thereafter.

If your machine is equipped with a Honda engine, read that owner's manual for maintenance.

OPERATION

Warm the Honda engine to operating temperature before splitting wood. Move the knife back and forth 2 or 3 times to ensure there is no air in the system.

Make sure that you have read and understood all safety recommendations before operating the machine.

If any unnecessary noise occurs stop operation immediately and check for damage. If nothing can be seen bring it to a dealer to inspect. If there is no dealer in your area, contact Split-fire Sales Inc. to discuss the problem.

Take a break every couple hours. Continuous work can create extra stress which can lead to an accident.

STORAGE

Important! When storing your log splitter special attention should be drawn to the areas listed below.

After each use, make sure that the inside of the frame is clean. Special attention should be drawn to the cylinder and slider. Looking from cylinder side of the log splitter you must be able to see light through the four corners of the tube. Wood chips and dirt can fill this up causing very high pressure. There are different ways to clean this out. If you do it regularly and everything stays dry in the frame you can blow it out with compressed air. If everything is wet in there you can take a pressure washer or hose to clean it out. Lastly you can use a small hooked rod to pull or push the chips out.

Keep knife closest to engine or 3 point hitch when in storage.

If storing for a long period of time you can spray a layer of light grade oil inside the frame and on the bed to prevent rusting.

If your machine is equipped with an engine, read that manual as well for storage tips.

POSI-LOCK COUPLER

OPERATION INSTRUCTIONS

Adjust coupler locking pressure on ball before use. Place handle in locked position with ball in coupler. Tighten locknut against tension spring so that coupler is not loose on ball. Correct adjustment will allow handle to be released with moderate pressure applied to handle.

To open, pull up on coupler handle and rotate forward. Place coupler on ball. When ball is completely nested in ball socket, rotate coupler handle backward until handle is in locked position.

After towing for 50 miles, check coupler for tightness on ball. Always check tightness before towing. Be sure coupler handle is in locked position.

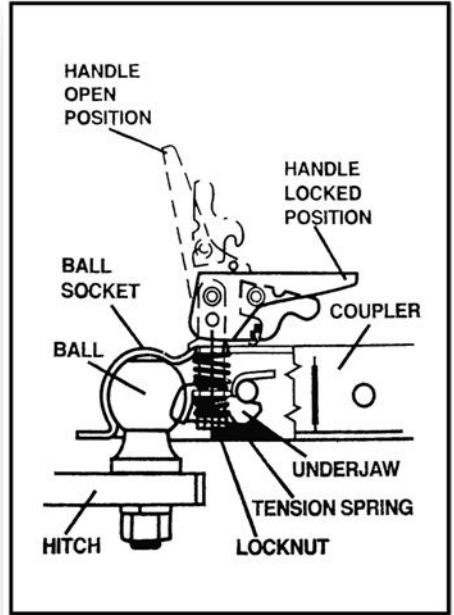

⚠ WARNING

FAILURE TO OBEY THESE RULES CAN CAUSE TRAILER TO DETACH WHILE TOWING WHICH MAY CAUSE SERIOUS INJURY OR DEATH!

NEVER EXCEED WEIGHT CAPACITY OF BALL OR LEAD LIMITS STAMPED ON COUPLER.

ALWAYS USE SAFETY CHAINS PERSUANT TO INSTRUCTIONS OF TRAILER MANUFACTURER.

ALWAYS USE CORRECT SIZE BALL SHOWN BY STAMP ON COUPLER.

ALWAYS CHECK THAT BALL IS COMPLETELY INSERTED INTO COUPLER SOCKET AND THAT UNDERJAW IS SECURELY CLOSED AROUND THE BOTTOM OF BALL.

ALWAYS CHECK THAT COUPLER HANDLE IS PROPERLY LOCKED BEFORE TOWING.

ALWAYS EXAMINE COUPLER AND BALL FOR DAMAGE BEFORE TOWING. REPLACE IF DAMAGED.

AVOID SHARP TURNS AND STEEP VERTICAL ANGLES WHEN TOWING WHICH MAY BEND OR DAMAGE COUPLER OR ITS COMPONENTS.

Towing Your Log Splitter

Note: Applies to all Highway Towable Units.

Log Splitters with Turf Tires are Not Intended for Road Towing.

Take extra care when hooking up and towing your log splitter.

Before towing, make sure your log splitter is in safe towing condition. Inspect the tires, bearings, lights, hitch, and safety chains.

Make sure the hitch is attached securely when attaching the log splitter to a vehicle. The hitch coupler and hitch ball should fit snug when locked.

Attach your log splitter to your vehicle with the hitch and safety chains. Make sure the safety chains cross under the hitch to prevent the hitch from dropping to the ground should the hitch disconnect. Chain hooks should have latches to prevent disconnect. Each chain should have a breaking strength equal to the gross weight of the log splitter.

Towing a log splitter puts additional weight on your vehicle. Increase the space around your vehicle to drive and stop safely.

When towing your log splitter, do avoid pot holes, curbs and all other obstacles. At some speeds, a sudden bump may result in an overturned log splitter.



General Parts List



Please indicate the log splitter model when ordering parts.

- 1 - 2" ball coupler
 - 2 - coupler latch assembly
 - 3 - safety chains & hooks
 - 4 - wire harness assembly
 - 5 - front stop assembly
 - 6 - stand assembly
 - 7 - stand locking pin
 - 8 - Transport Canada VIN certification
 - 9 - knife and slider assembly
 - 10 - log shelf (2)
 - 11 - frame assembly
 - 12 - slide pad kit
 - 13 - rubberride suspension
(non-rubberride: 1" spindle,
LS models: 3/4" spindle)
 - 14 - rear stop assembly
 - 15 - decal kit (6 pc.)
 - 16 - high pressure hose
 - 17 - hydraulic oil filler tube
 - 18 - valve handle assembly
 - 19 - breather cap
- hydraulic valve assembly - 20
 - hydraulic steel line (1 short & 1 long) - 21
 - rubberride axle assembly - 22
 - filter head - 23
 - oil filter canister - 24
 - hydraulic pump - 25
 - hydraulic oil reservoir - 26
 - hydraulic return hose - 27
 - hydraulic suction hose - 28
 - pump adapter - 29
 - Honda Engine (see Honda manual) - 30
 - high speed tire - turf tires on LS models (2) - 31
 - If reordering high speed tires, indicate 4
or 5 bolt.
 - bumper - 32
 - high speed hub assembly (2) - 33
 - light box (2; left and right) - 34
 - tail light (2; left and right) - 35
 - reservoir sight glass (not shown) - 36
 - coupler assembly between - 37
 - pump & engine (3 pc.)

Machine Operator Safety Checklist

1. Each person that operates this Split-fire log splitter must read and understand this checklist and the rest of the owner's manual before operation.
2. Handle wood on the bark side only. Never pick up or handle logs by the sawn ends. Handling logs by the sawn ends may result in injury and/or death.
3. Keep hands at least 6 inches away from the stops and the knife at all times.
4. Always wear ear, eye, hand, and foot protection when operating the log splitter. Never wear loose clothing.
5. Do not tamper with engine RPM or pressure settings as the oil may overheat and cause leakage. This may result in reduced splitting power and could cause damage to the log splitter.
6. Keep the working area around the log splitter organized and free of equipment, tools, wood, and debris. Not doing so could result in injury or death.
7. Do not lift logs that are beyond your lifting capability. To reduce strain and/or injury, flip up the log splitter stand and lower the hitch to the ground. Roll the log onto the log splitter using the lower corner of the shelf as a lever.
8. Before towing the log splitter, make sure the hitch and safety chains are securely fastened (remember to cross the safety chains). Do not tow with the engine running and close the fuel shutoff lever on the engine prior to towing.
9. Take frequent breaks when using the log splitter. Stress and fatigue can result in injury and/or death. Be awake and alert at all times.

I have read and fully understand all of the above.

Customer/Operator Signature: _____

Date: _____ / _____ / 20_____

